

I. UPPER KNIFE & CLOTH FEED COMPONENTS

上メス、布送り関係

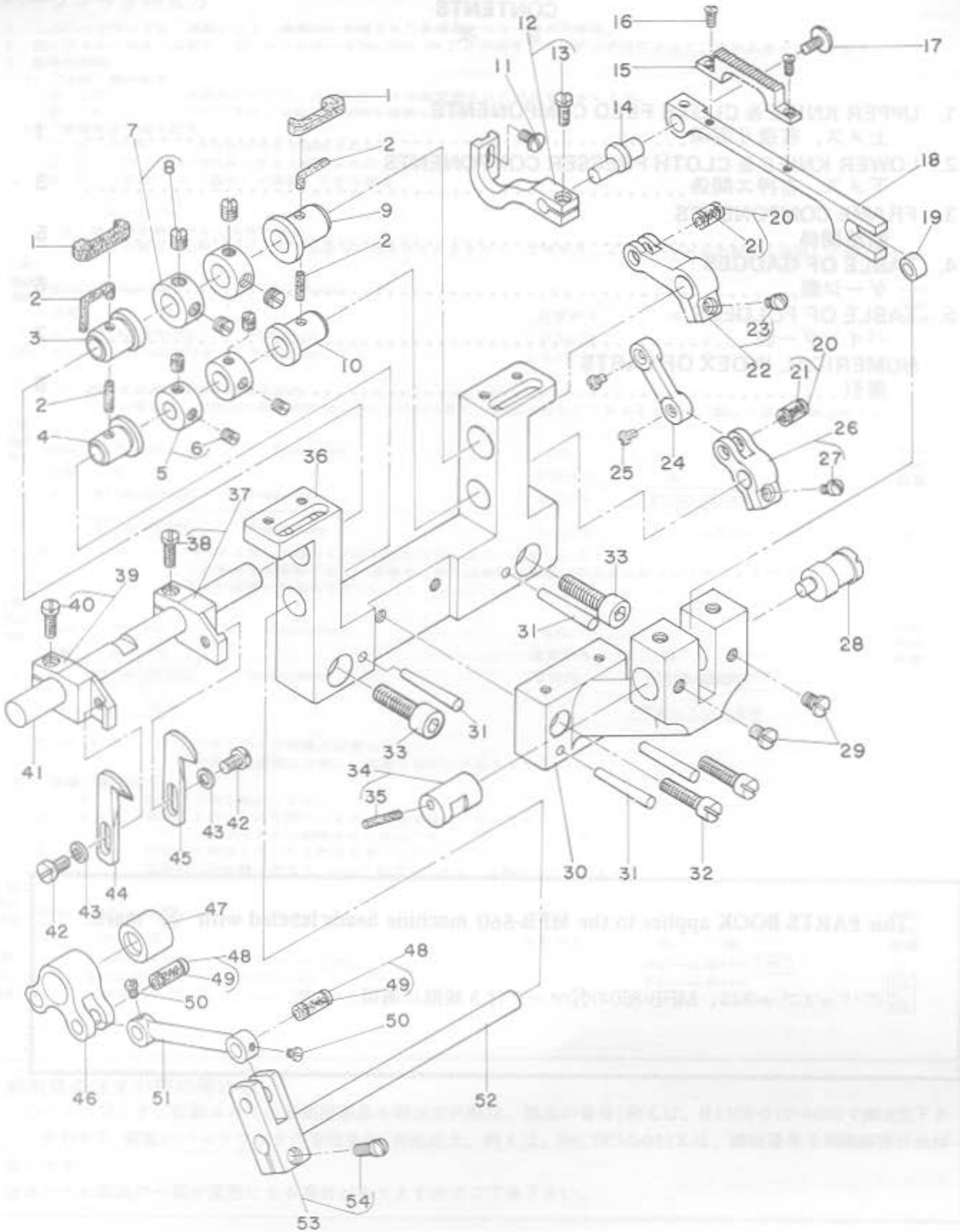

Ref. No.	Note 注記	Part No. 品番	Description	E. C. 変更年月	品名	Amt. Req. 数量
1		MAS-11064000	OIL FELT		アブラマシ フイルト	2
2		CQ-3000000-FO	OIL FELT		ロフト フイルト	0.1
3		MAS-11003000	UPPER BUSHING, LEFT		ウメタ& (ヒタリ)	1
4		MAS-11005000	LOWER BUSHING, LEFT		シタメタ& (ヒタリ)	1
5		CS-079101C-SH	THRUST COLLAR ASM, D=7,94 W=10		スラストウケ D=7,94 W=10 ク&E	2
6		SS-8110510-SP	SCREW 11/64-40 L=5		トメジ& 11/64-40 L=5	(4)
7		CS-111101A-SH	THRUST COLLAR ASM, D=11,11 W=10		スラストウケ D=11,11 W=10 ク&E	2
8		SS-8660410-TP	SCREW 1/4-40 L=4,2		トメジ& 1/4-40 L=4,2	(4)
9		MAS-11004000	UPPER BUSHING, RIGHT		ウメタ& (ヒタ)	1
10		MAS-11006000	LOWER BUSHING, RIGHT		シタメタ& (ヒタ)	1
11	*	SS-7090850-SP	SCREW 9/64-40 L=8	D,12/79	SS-7090710-SP	-
	*	SS-7090710-SP	SCREW 9/64-40 L=6,8	A,12/79	マ&ヒラジ& 9/64-40 L=6,8	1
12		MAS-11023080	FEED ARM ASM,		オクリウチ ク&E	1
13		SS-7111120-SP	SCREW 11/64-40 L=10,5		マ&ヒラジ& 11/64-40 L=10,5	(1)
14		MAS-11025000	FEED PLATE CONNECTING LINK		ヌノクリ リンクツシ&ク	1
15	001	MAS-1103500A	CLOTH FEED A		ヌノクリ A	1
16		SS-2090710-SP	SCREW 9/64-40 L=7		マ&ヒラジ& 9/64-40 L=7	2
17		SS-5110710-SP	SCREW 11/64-40 L=7		トラスジ& 11/64-40 L=7	1
18		MAS-11024000	FEED BAR		ヌノクリタ&イ	1
19		B1611-3&2-000	DIFFERENTIAL FEED BAR ROLLER		フクオクリ ヨ&	1
20		MAS-110320A0	PIN ASM,		メ&ス ヨ&-リンクヒ&ン ク&E	2
21		CQ-3000000-FO	OIL FELT		ロフト フイルト	(0.1)
22		MAS-110310A0	FEED ROCKER ARM ASM,, UPPER		メ&ス ヨ&-ウツ&ク ク&E	1
23		SS-7110720-SP	SCREW 11/64-40 L=7		マ&ヒラジ& 11/64-40 L=7	(1)
24		MAS-11030000	FEED ROCKER LINK		メ&ス ヨ&-リンク	1
25		SS-6080410-SP	SCREW 1/8-44 L=4		ヒラジ& 1/8-44 L=4	2
26		MAS-110290A0	FEED ROCKER ARM ASM,, LOWER		メ&ス ヨ&-ウツ&ク ク&E	1
27		SS-7110720-SP	SCREW 11/64-40 L=7		マ&ヒラジ& 11/64-40 L=7	(1)
28		MAS-11009000	FEED SHAFT		オクリ ウツ&ク	1
29		SS-7150740-SP	SCREW 15/64-28 L=7		マ&ヒラジ& 15/64-28 L=7	2
30		MAS-11002000	TABLE SUPPORT ARM		チ&-フ&ウケ	1
31		PT-0403200-SH	TAPERED PIN 4,0X32		チ&-ハ&ヒ&ン 4X32	4
32		SS-6152440-SP	SCREW 15/64-28 L=23,5		ヒラジ& 15/64-28 L=23,5	2
33		SM-6082502-TM	SCREW M8 L=25		ロツ&クア&ア&ヒ&ト M8 L=25	2
34		MAS-110070A0	REGULATING SHAFT ASM,		チ&-ヨ&-セツ&ク ク&E	1
35		CQ-3000000-FO	OIL FELT		ロフト フイルト	(0.1)
36		MAS-11001000	BASE		ト&タ&イ	1
37		MAS-110110A0	UPPER KNIFE BASE ASM,, RIGHT		ウツ&メ&ス トリツ&ク&タ&イ ヒ&タ ク&E	1
38		SS-7111120-SP	SCREW 11/64-40 L=10,5		マ&ヒラジ& 11/64-40 L=10,5	(1)
39		MAS-110100A0	UPPER KNIFE BASE ASM,, LEFT		ウツ&メ&ス トリツ&ク&タ&イ ヒ&タリ ク&E	1
40		SS-7111120-SP	SCREW 11/64-40 L=10,5		マ&ヒラジ& 11/64-40 L=10,5	(1)
41		MAS-11047000	DIFFERENTIAL FEED SHAFT		メ&ス フ&ト&-ヒ&ク	1
42		SS-7110840-SP	SCREW 11/64-40 L=7,8		マ&ヒラジ& 11/64-40 L=7,8	2
43	*	WP-0460556-SD	WASHER 4,6X7,5X0,5	D,12/79	WP-0450000-SD	-
	*	WP-0450000-SD	WASHER 4,5X8X0,5	A,12/79	ヒラジ&カ& 4,5X8X0,5	2
44		MAS-11012000	UPPER KNIFE, LEFT		ウツ&メ&ス (ヒ&タ)	1
45		MAS-11013000	UPPER KNIFE, RIGHT		ウツ&メ&ス (ヒ&タ)	1
46		MAS-11028000-A	FEED CRANK LINK		チ&-ヨ&-セツ&ク リンク	1
47		MAS-11069000	NEEDLE BEARING		チ&-ヨ&-セツ&ク ニ&-ト&&	1
48	002	B2527-860-BA0	PIN ASM,		ヨ&-ト&-リンクヒ&ン ク&E	2
49		CQ-3000000-FO	OIL FELT		ロフト フイルト	(0.1)
50		SS-6080410-SP	SCREW 1/8-44 L=4		ヒラジ& 1/8-44 L=4	2
51		MAS-11027000	DRIVING LINK		ク&ト&-リンク	1
52		MAS-11048000	FEED ROCKER SHAFT		メ&ス ヨ&-ト&-ヒ&ク	1
53		MAS-11026080	DRIVING ARM ASM,		ク&ト&-ロフト ク&E	1
54		SS-7111410-SP	SCREW 11/64-40 L=14		マ&ヒラジ& 11/64-40 L=14	(1)

Note. (注記) 001. For further details refer to pages 6 & 7.
002. Selecting part

詳しくは、P6、P7を御参照下さい。
選択部品

2. LOWER KNIFE & CLOTH PRESSER COMPONENTS

下メス、布押工関係

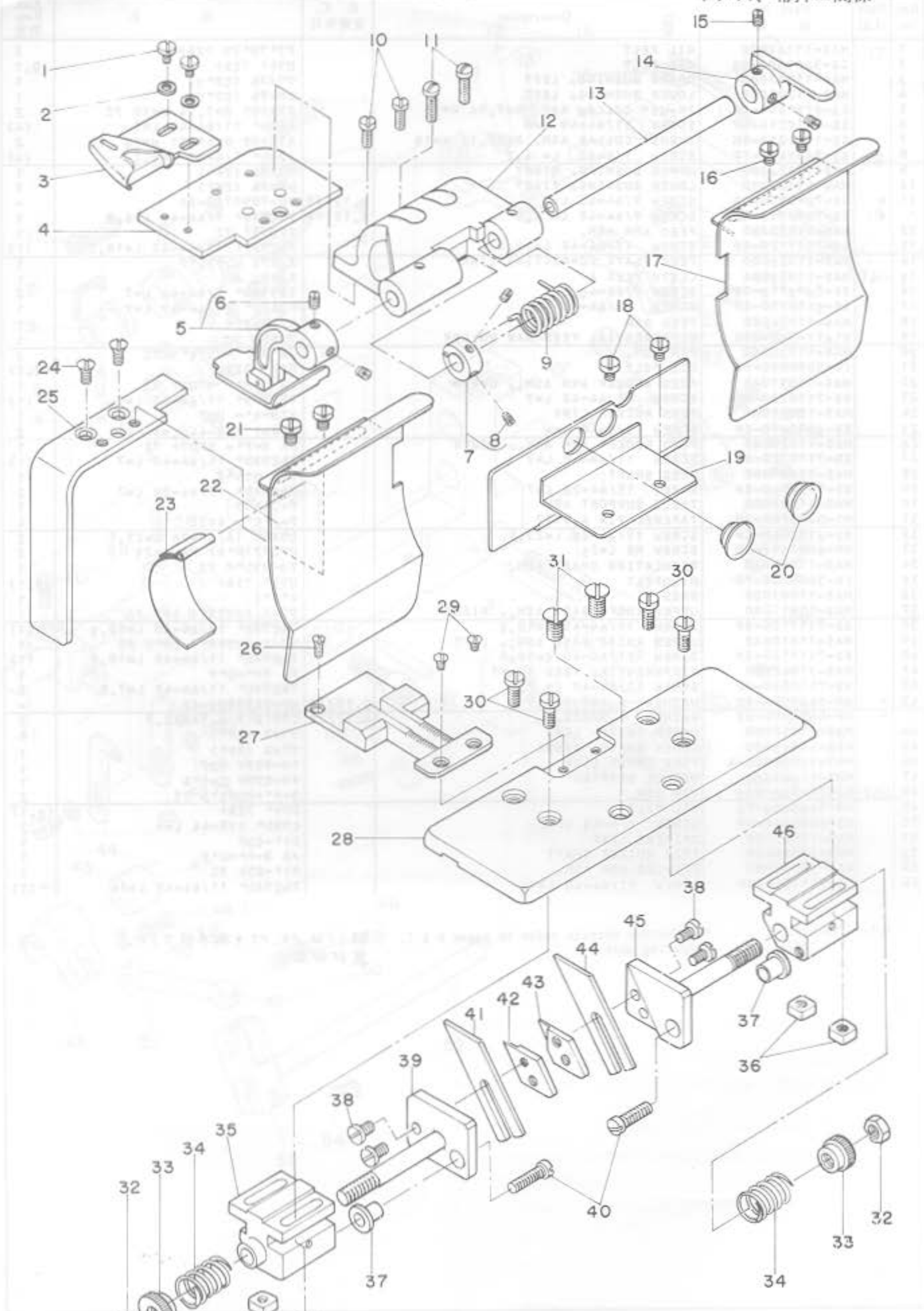

4. TABLE OF PARTS

Ref. No.	Note	Part No. 品番	Description	E. C. 変更年月	品名	Amt. Req. 個数
1		SS-7090540-TP	SCREW 9/64-40 L= 5.0		ワシワシ 9/64-40 L= 5	2
2		UP-0450000-SD	WASHER 4,5X8,0X0,5		ワシワシ 4,5X8,0X0,5	2
3	001	HAS-1100M00B	FOLDER 12MM B		ハインク 12ミリ (チューブ用)	1
4		HAS-11037000	RIGHT COVER		ミキカハ	1
5	001	HAS-110340AM	CLOTH PRESSER ASM. M		ミキカハ M クミ	1
6		SS-8110510-SP	SCREW 11/64-40 L= 5.0		トメジメ 11/64-40 L= 5	(2)
7		HAS-110430A0	COLLAR ASM.		ハネツメ クミ	1
8		SS-8090540-SP	SCREW 9/64-40 L= 5.0		トメジメ 9/64-40 L= 5	(2)
9		HAS-11044000	SPRING		ミキカハ	1
10		SS-7111120-SP	SCREW 11/64-40 L=10,5		ワシワシ 11/64-40 L=10,5	2
11		SS-7111140-SP	SCREW 11/64-40 L=14,0		ワシワシ 11/64-40 L=14	2
12		HAS-11038000	PRESSER BASE		ミキカハ	1
13		B2002-038-000	LOOPER ROCKER SHAFT		ルーパーシャフト	1
14		HAS-11042000	PRESSER LIFTING LEVER		ミキカハ	1
15		SS-8110510-SP	SCREW 11/64-40 L= 5.0		トメジメ 11/64-40 L= 5	2
16		SS-7110510-SP	SCREW 11/64-40 L= 5.0		ワシワシ 11/64-40 L= 5	2
17		HAS-11046000	CLOTH COVER, RIGHT		ミカハ (ミキ)	1
18		SS-7110510-SP	SCREW 11/64-40 L= 5.0		ワシワシ 11/64-40 L= 5	2
19		HAS-11054000	CHIP GUARD COVER		ミカハ	1
20		B1156-850-000	RUBBER PLUG		メンタ プラグ	2
21		SS-7110510-SP	SCREW 11/64-40 L= 5.0		ワシワシ 11/64-40 L= 5	2
22		HAS-11045000	CLOTH COVER, LEFT		ミカハ (ミキ)	1
23		HAS-11062000	AUXILIARY CLOTH COVER		ミカハ	1
24		SS-2110920-TP	SCREW 11/64-40 L= 8,5		ワシワシ 11/64-40 L= 8,5	2
25		HAS-11036000	LEFT COVER		ミカハ	1
26		SS-2090810-SP	SCREW 9/64-40 L= 7,5		ワシワシ 9/64-40 L= 7,5	1
27	001	HAS-1103300A	FEED PLATE A		ミカハ A	1
28		HAS-11022000	TABLE		テーブル	1
29		SS-2090530-SP	SCREW 9/64-40 L= 4,8		ワシワシ 9/64-40 L= 4,8	2
30		SS-6121220-TP	SCREW 3/16-28 L=11,5		ワシワシ 3/16-28 L=11,5	4
31		SS-1681140-SP	SCREW 9/32-28 L=11,0		ワシワシ 9/32-28 L=11	2
32		NS-6680320-SP	NUT 9/32-28		ナット 9/32-28	2
33		HAS-11052000	SPRING REGULATOR		ハネ 53-セツ	2
34		HAS-11049000	SPRING		メスハネ	2
35		HAS-11014000	LOWER KNIFE BASE, LEFT		ミカハ (ミキ)	1
36		HAS-11040000	NUT		ナット	4
37		HAS-11053000	ROTATION STOPPER		ミカハ	2
38		SS-7110840-SP	SCREW 11/64-40 L= 7,8		ワシワシ 11/64-40 L= 7,8	4
39		HAS-11018000	LOWER KNIFE HOLDER, LEFT		ミカハ トリツケ (ミキ)	1
40		SS-7111810-SP	SCREW 11/64-40 L=18,0		ワシワシ 11/64-40 L=18	2
41		HAS-11016000	LOWER KNIFE, LEFT		ミカハ (ミキ)	1
42		HAS-11020000	LOWER KNIFE SET PLATE, LEFT		ミカハ トメタ (ミキ)	1
43		HAS-11021000	LOWER KNIFE SET PLATE, RIGHT		ミカハ トメタ (ミキ)	1
44		HAS-11017000	LOWER KNIFE, RIGHT		ミカハ (ミキ)	1
45		HAS-11019000	LOWER KNIFE HOLDER, RIGHT		ミカハ トリツケ (ミキ)	1
46		HAS-11015000	LOWER KNIFE BASE, RIGHT		ミカハ (ミキ)	1

Note. (注記) 001. For further details refer to pages 6-7. 詳しくは、P6、P7を御参照下さい。

3. FRAME COMPONENTS

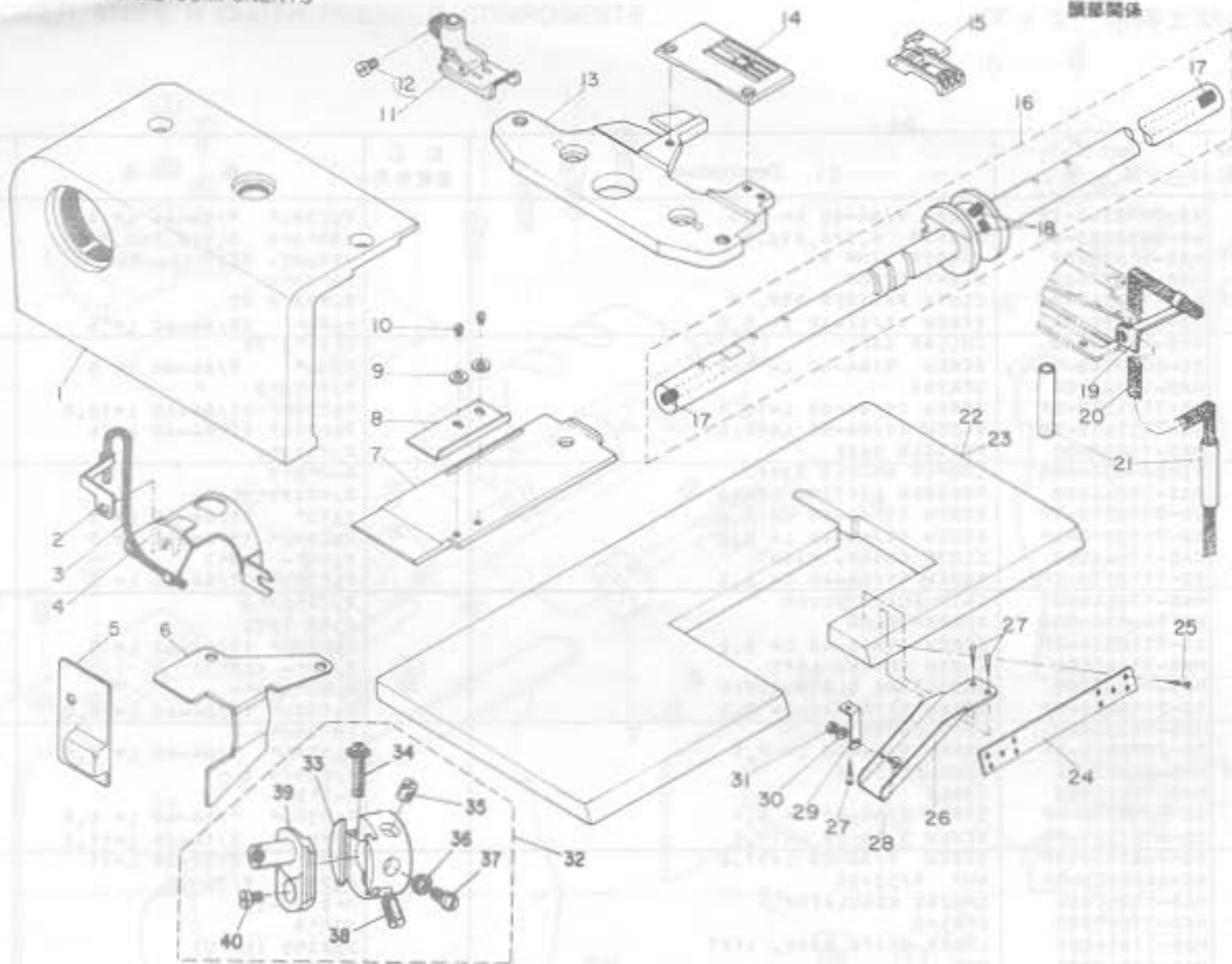

Ref. No.	Note	Part No.	Description	E. C. 変更年月	品名	Amt. Req. 数量
1		HAS-11050000	END COVER		エンドカバー	1
2		B3506-761-000	OIL WICK HOLDER		オイルウイックホルダー	1
3		CQ-3000000-P0	OIL FELT		オイルフェルト	0.2
4		HAS-11055000	FEED CAM OIL SHIELD		送りカムオイルシールド	1
5		HAS-11056000	LOOPER OIL SHIELD, LEFT		ルーパーオイルシールド(左)	1
6		HAS-11067000	LOOPER OIL SHIELD, RIGHT		ルーパーオイルシールド(右)	1
7		HAS-11057000	SLIDE PLATE		スライドプレート	1
8		HAS-11058000	SLIDE PLATE COVER		スライドプレートカバー	1
9		WP-0250516-S0	WASHER 2.5X6X0.5		ワッシャー 2.5X6X0.5	2
10		SS-5060310-SP	SCREW 3/32-56 L=2.8		ネジ 3/32-56 L=2.8	2
11	001	R5212-P06-0AP	PRESSER FOOT ASM, G12		プレッサーフット組立	1
12		SS-6090670-TP	SCREW 9/64-40 L=6		ネジ 9/64-40 L=6	(1)
13		HAS-11051000	THROAT PLATE BASE		ノズルプレートベース	1
14	001	R4253-P06-G0P	THROAT PLATE (GG8)		ノズルプレート (GG8)	1
15	001	R0000-P0F-40P	FEED DOG (F,G)		送り爪	1
16		HAS-110680A0	LOWER SHAFT ASM,		シャフト組立	1
17		TA-0500601-H0	PLUG D=5X5.4 L=6		プラグ D=5X5.4 L=6	(2)
18		TA-0290601-H0	PLUG D=2.9X3.2 L=6		プラグ D=2.9X3.2 L=6	(2)
19		B3506-761-000	OIL WICK HOLDER		オイルウイックホルダー	1
20		B3541-012-000	OIL WICK		オイルウイック	1
21		B3522-850-000	OIL PIPE		オイルパイプ	2
22	003	B8201-850-00E	TABLE E		テーブルE	1
23	004	B8201-850-00F	TABLE F		テーブルF	1
24		HAS-11061000	TABLE REINFORCEMENT PLATE		テーブル強化プレート	1
25		SK-1382500-SC	WOOD SCREW D=3.8 L=25		木ネジ D=3.8 L=25	10
26		HAS-11059000	CHIP SHUTE		スリットカバー	1
27		SK-3482500-SC	WOOD SCREW D=4.8 L=25		木ネジ D=4.8 L=25	3
28		SS-5110710-SP	SCREW 11/64-40 L=7		ネジ 11/64-40 L=7	1
29		HAS-11060000	CHIP SHUTE SET PLATE		スリットカバーセットプレート	1
30		WP-0480856-SP	WASHER 4.8X8.4X0.8		ワッシャー 4.8X8.4X0.8	1
31		NS-6110310-SP	NUT 11/64-40		ナット 11/64-40	1
32	*	HAS-110750A0	FEED CRANK STUD BODY ASM.	A.05/80	送り曲がり軸受組立	1
33	*	B1611-850-000	FEED CRANK STUD BODY	A.05/80	送り曲がり軸受	(1)
34	*	HAS-110760A0	STITCH REGULATING SCREW ASM.	A.05/80	送り調節ネジ組立	(1)
35	*	SS-8150710-SP	SCREW 15/64-28 L=7	A.05/80	ネジ 15/64-28 L=7	(1)
36	*	WP-0482086-S0	WASHER 4.8X11.5X2.0	A.05/80	ワッシャー 4.8X11.5X2.0	(1)
37	*	SS-7110630-TP	SCREW 11/64-40	A.05/80	ネジ 11/64-40	(1)
38	*	SS-8151150-SP	SCREW 15/64-28 L=10.5	A.05/80	ネジ 15/64-28 L=10.5	(1)
39	*	HAS-11075000	FEED CRANK STUD	A.05/80	送り曲がり軸受	(1)
40	*	SS-6090640-SP	SCREW 9/64-40 L=6.0	A.05/80	ネジ 9/64-40 L=6.0	(1)

Note. (注記) 001. For further details refer to pages 6 & 7. 詳しくは、P6、P7を参照下さい。
 003. For clutch motor クラッチモーター用
 004. For needle positioning motor ストップモーター用

* All parts other than the above are same as those of model MF-860.
 上記以外の部品は、MF-860と同一です。

4. TABLE OF GAUGES

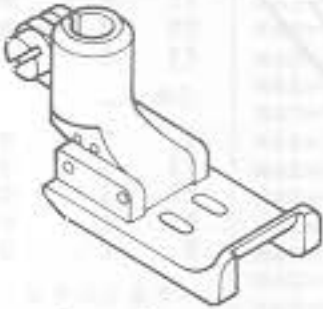
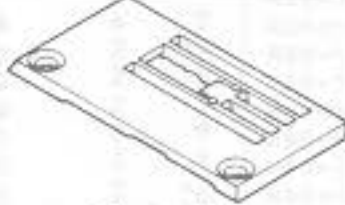
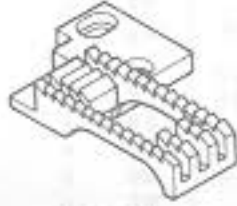
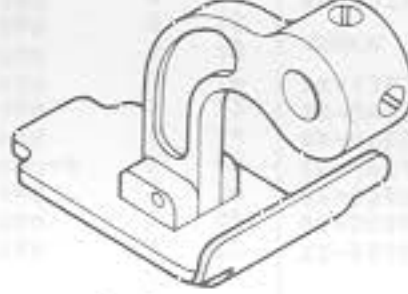
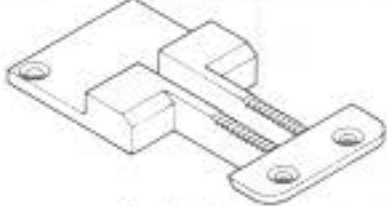
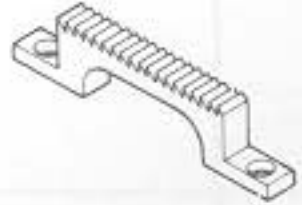
No.	Description 品名	Finished width & Material 仕上り幅 及び厚サ	Needle gauge 針幅		
			F 4.8 mm (3/16")	G 5.6 mm (7/32")	H 6.4 mm (1/4")
1	 Needle clamp asm. 針留(組)		B1409-860-FA0	B1409-860-GA0	B1409-860-HA0
2	 Presser foot asm. 押エ(組)	8 mm (5/16")	*R5208-F0F-0AP		
		10 mm (25/64")	R5210-F0F-0AP	R5210-F0G-0AP	R5210-F0H-0AP
		12 mm (15/32")	R5212-F0F-0AP	R5212-F0G-0AP	R5212-F0H-0AP
		15 mm (19/32")		R5215-F0G-0AP	R5215-F0H-0AP
		18 mm (45/64")			*R5218-F0H-0AP
		20 mm (25/32")			*R5220-F0H-0AP
3	 Throat plate 針板	Standard 標準	R4253-F0F-G0P	R4253-F0G-G0P	R4253-F0H-G0P
		Heavy-weight material 厚物		R4250-F0G-J0P	R4250-F0H-J0P
4	 Feed dog 送り歯		R6000-F0F-40P	R6000-F0H-40P	
5	 Cloth presser asm. 布押エ(組)	8 mm (5/16")		*MAS-110340AH	
		10 mm (25/64")		MAS-110340AK	
		12 mm (15/32")		MAS-110340AM	
		15 mm (19/32")		MAS-110340AQ	
		18 mm (45/64")		*MAS-110340AT	
		20 mm (25/32")		*MAS-110340AV	
6	 Feed plate 布送り板	14 mm or less (35/64") 14mm以下		MAS-1103300A	
		15 mm or more (19/32") 15mm以上		MAS-1103300B	
7	 Cloth feed 布送り	14 mm or less (35/64") 14mm以下		MAS-1103500A	
		15 mm or more (19/32") 15mm以上		MAS-1103500B	
		12 mm or more (15/32") 12mm以上		MAS-1103500C	

*..... Special order part 特別注文部品

5. TABLE OF FOLDERS

バインダー表

Type of material 厚サ		Finished width 仕上り幅	H	K	M	Q	T	V
			8 mm (5/16")	10 mm (25/64")	12 mm (15/32")	15 mm (19/32")	18 mm (45/64")	20 mm (25/32")
A	Light-weight material 薄物	Part No. 品番	*MAS-1100H00A	*MAS-1100K00A	*MAS-1100M00A			
B	Medium-heavy weight material 中厚物	Part No. 品番	*MAS-1100H00B	MAS-1100K00B	MAS-1100M00B	*MAS-1100Q00B	*MAS-1100T00B	
H	Heavy-weight material 厚物	Part No. 品番			MAS-1100M00H	MAS-1100Q00H	*MAS-1100T00H	*MAS-1100V00H

* Special order part.
Please consult us for other sizes the listed above.

特別注文部品
上記以外のサイズについても御相談をうけたまわります。

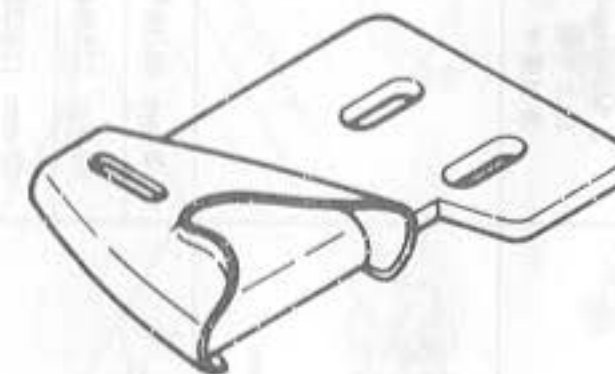

NUMERICAL INDEX OF PARTS

索引

Part No. 品番	Page 頁	Ref. No.	Part No. 品番	Page 頁	Ref. No.	Part No. 品番	Page 頁	Ref. No.	Part No. 品番	Page 頁	Ref. No.
EXCLUSIVE PARTS "B" 専用部品 "B"			MAS-110320A0	2	20	SS-2110920-TP	4	24			
B1156-850-000	4	20	MAS-1103300A	4	27	SS-5060310-SP	5	10			
B1611-352-000	2	19	MAS-110340AM	4	5	SS-5110710-SP	2	17			
B1611-850-000	5	33	MAS-1103500A	2	15	SS-5110710-SP	5	28			
B2002-038-000	4	13	MAS-11036000	4	25	SS-6080410-SP	2	25			
B2527-860-8A0	2	48	MAS-11037000	4	4	SS-6080410-SP	2	50			
B3506-761-000	5	2	MAS-11038000	4	12	SS-6090640-SP	5	40			
B3506-761-000	5	19	MAS-11040000	4	36	SS-6090670-TP	5	12			
B3522-850-000	5	21	MAS-11042000	4	14	SS-6121220-TP	4	30			
B3541-012-000	5	20	MAS-110430A0	4	7	SS-6152440-SP	2	32			
B8201-850-00E	5	22	MAS-11044000	4	9	SS-7090540-TP	4	1			
B8201-850-00F	5	23	MAS-11045000	4	22	SS-7090710-SP	2	11			
OIL WICK		油心	MAS-11046000	4	17	SS-7090850-SP	2	11			
CQ-3000000-FO	2	2	MAS-11047000	2	41	SS-7110510-SP	4	16			
CQ-3000000-FO	2	21	MAS-11048000	2	52	SS-7110510-SP	4	18			
CQ-3000000-FO	2	35	MAS-11049000	4	34	SS-7110510-SP	4	21			
CQ-3000000-FO	2	49	MAS-11050000	5	1	SS-7110630-TP	5	37			
CQ-3000000-FO	5	3	MAS-11051000	5	13	SS-7110720-SP	2	23			
THRUST COLLAR		スラストカラー	MAS-11052000	4	33	SS-7110720-SP	2	27			
CS-079101C-SH	2	5	MAS-11053000	4	37	SS-7110840-SP	2	42			
CS-111101A-SH	2	7	MAS-11054000	4	19	SS-7110840-SP	4	38			
EXCLUSIVE PARTS "M" 専用部品 "M"			MAS-11055000	5	4	SS-7111120-SP	2	13			
MAS-1100M00B	4	3	MAS-11056000	5	5	SS-7111120-SP	2	38			
MAS-11001000	2	36	MAS-11057000	5	7	SS-7111120-SP	2	40			
MAS-11002000	2	30	MAS-11058000	5	8	SS-7111120-SP	4	10			
MAS-11003000	2	3	MAS-11059000	5	26	SS-7111410-SP	2	54			
MAS-11004000	2	9	MAS-11060000	5	29	SS-7111410-SP	4	11			
MAS-11005000	2	4	MAS-11061000	5	24	SS-7111810-SP	4	40			
MAS-11006000	2	10	MAS-11062000	4	23	SS-7150740-SP	2	29			
MAS-110070A0	2	34	MAS-11064000	2	1	SS-8090540-SP	4	8			
MAS-11009000	2	28	MAS-11067000	5	6	SS-8110510-SP	2	6			
MAS-110100A0	2	39	MAS-110680A0	5	16	SS-8110510-SP	4	6			
MAS-110110A0	2	37	MAS-11069000	2	47	SS-8110510-SP	4	15			
MAS-11012000	2	44	MAS-110750A0	5	32	SS-8150710-SP	5	35			
MAS-11013000	2	45	MAS-11075000	5	39	SS-8151150-SP	5	38			
MAS-11014000	4	35	MAS-110760A0	5	34	SS-8660410-TP	2	8			
MAS-11015000	4	46	NUT		ナット	PLUG		止メ栓			
MAS-11016000	4	41	NS-6110310-SP	5	31	TA-0290601-H0	5	18			
MAS-11017000	4	44	NS-6680320-SP	4	32	TA-0500601-H0	5	17			
MAS-11018000	4	39	PIN		ピン	WASHER		座金			
MAS-11019000	4	45	PT-0403200-SH	2	31	WP-0250516-SD	5	9			
MAS-11020000	4	42	EXCLUSIVE PARTS "R" 専用部品 "R"			WP-0450000-SD	2	43			
MAS-11021000	4	43	R4253-FOG-GOP	5	14	WP-0450000-SD	4	2			
MAS-11022000	4	28	R5212-FOG-0AP	5	11	WP-0460556-SD	2	43			
MAS-110230B0	2	12	R6000-FOF-40P	5	15	WP-0480856-SP	5	30			
MAS-11024000	2	18	SCREW		ネジ	WP-0482086-SD	5	36			
MAS-11025000	2	14	SK-1382500-SC	5	25						
MAS-110260B0	2	53	SK-3482500-SC	5	27						
MAS-11027000	2	51	SM-6082502-TM	2	33						
MAS-11028000-A	2	46	SS-1681140-SP	4	31						
MAS-110290A0	2	26	SS-2090530-SP	4	29						
MAS-11030000	2	24	SS-2090710-SP	2	16						
MAS-110310A0	2	22	SS-2090810-SP	4	26						